

1 LEXUS SC400/SC300 ELECTRICAL WIRING DIAGRAM

(Cont. next page)

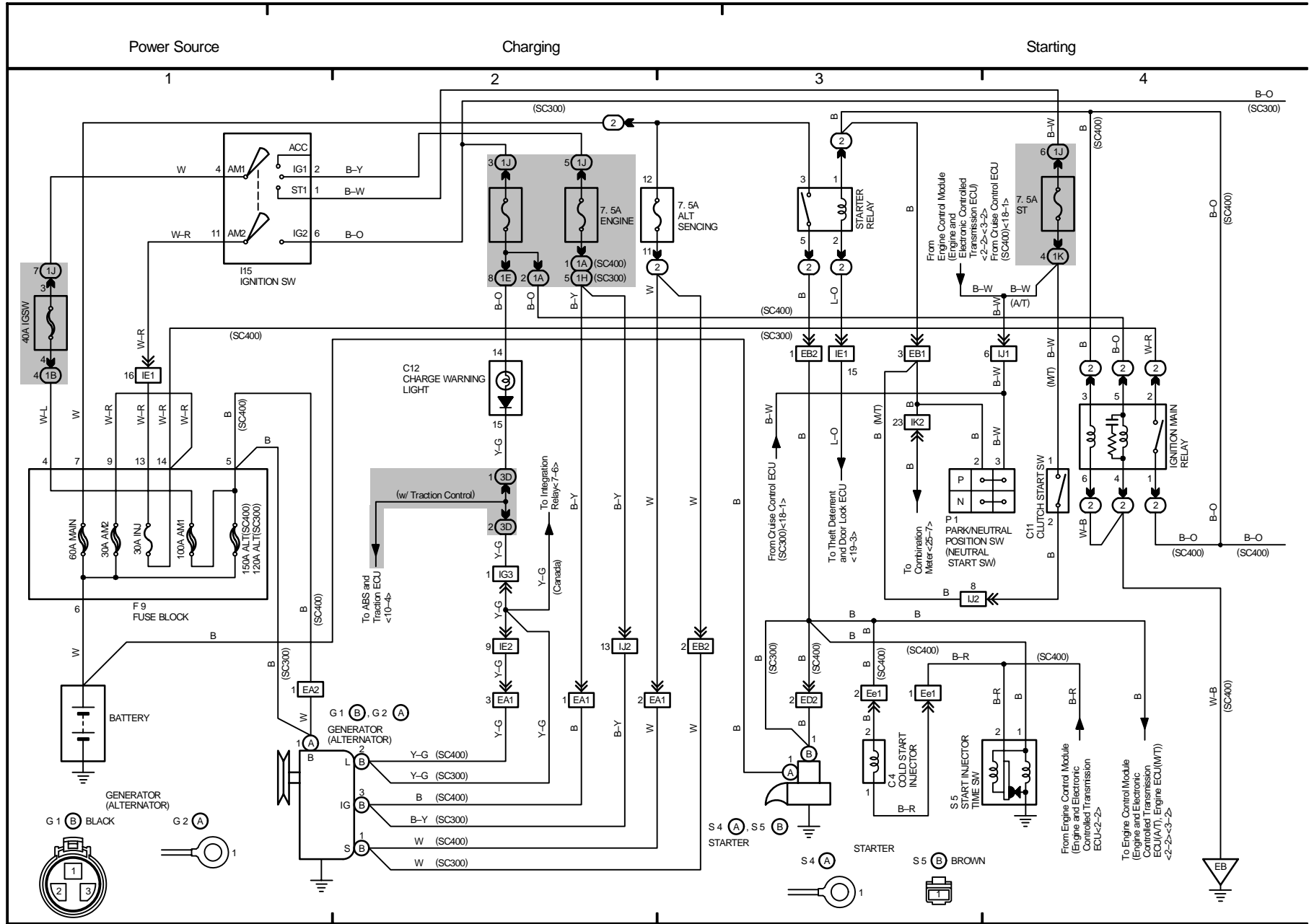

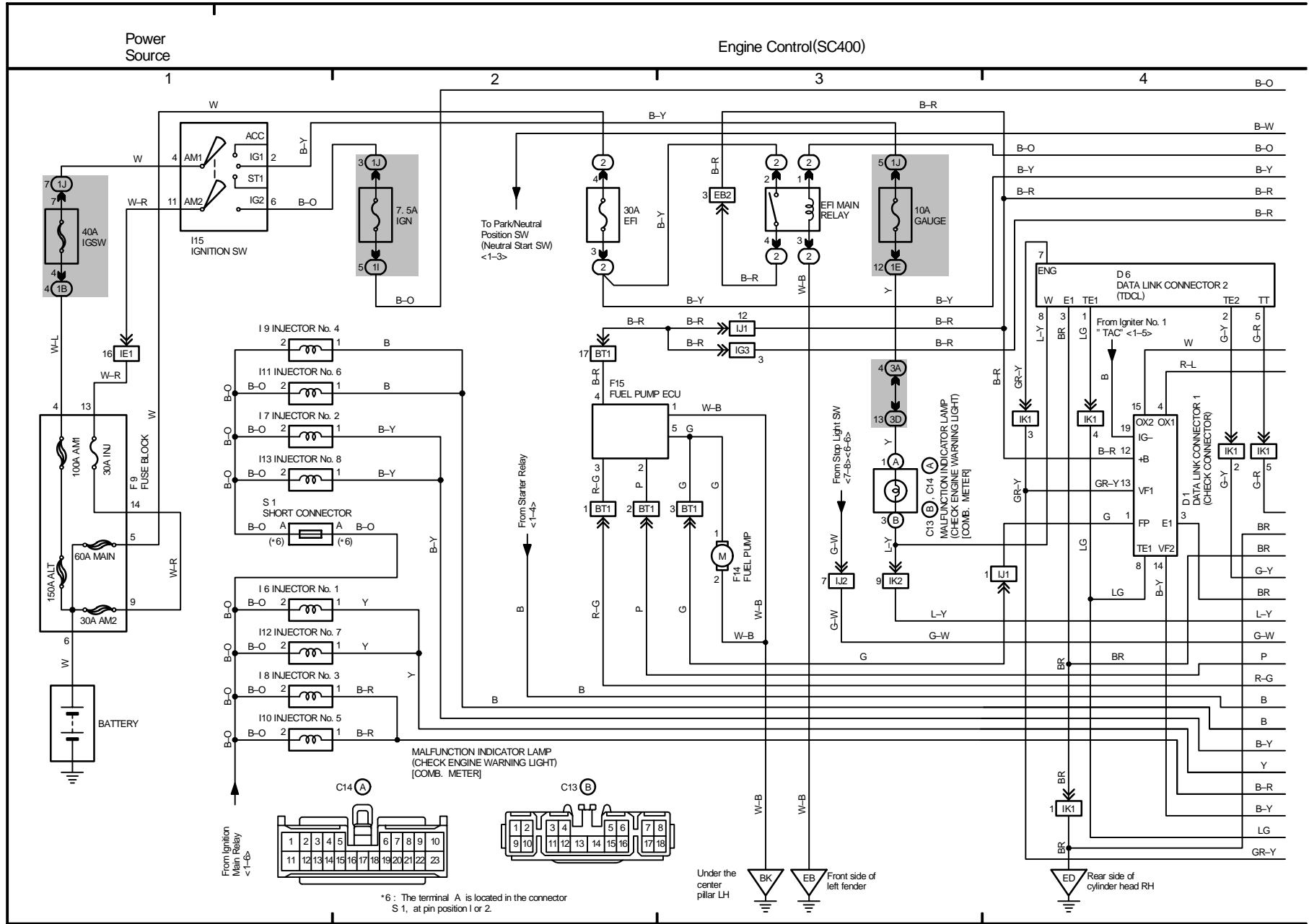

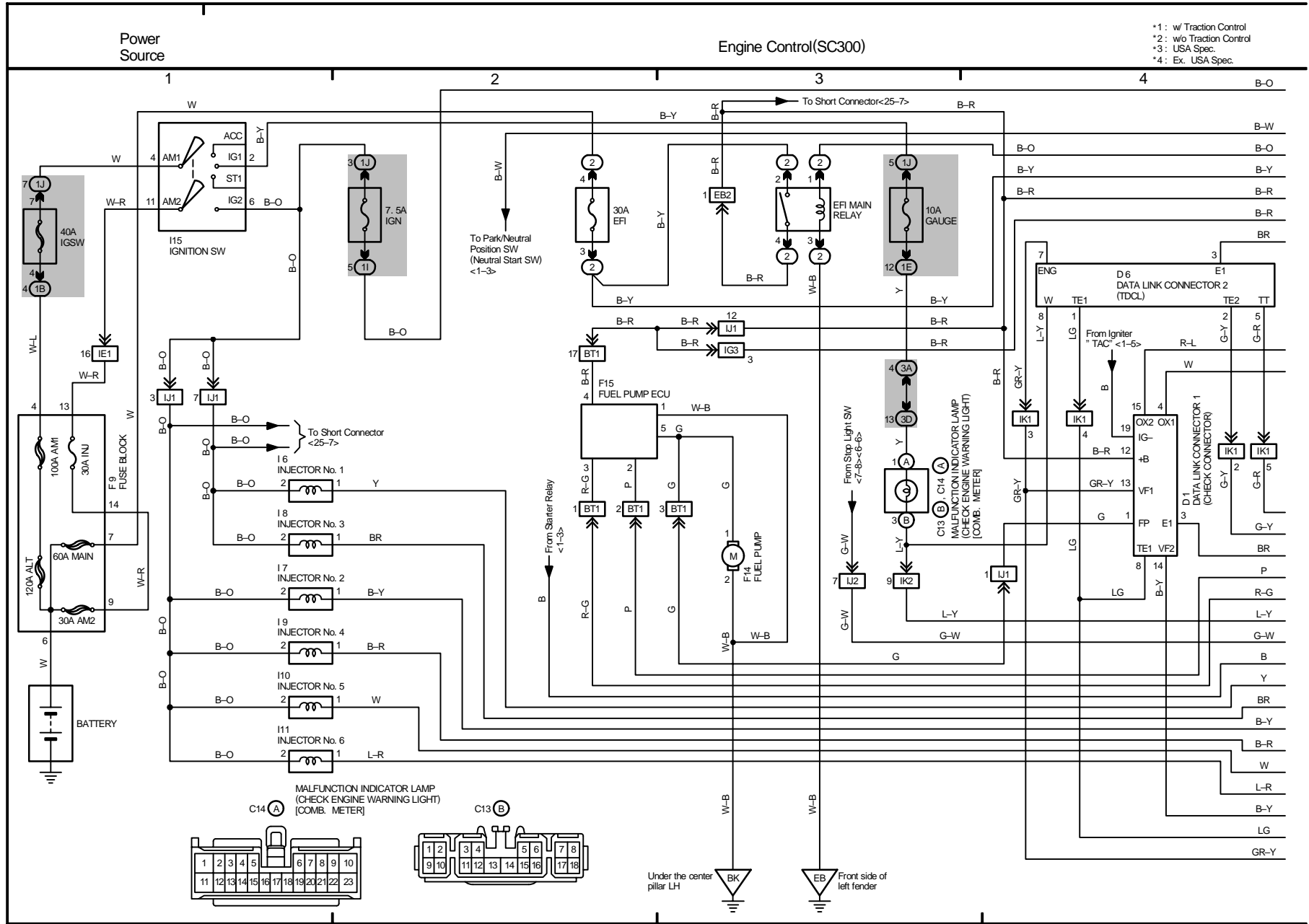

4 LEXUS SC400/SC300(Cont' d)

Electronic Controlled Transmission and A/T Indicator(SC400)

Back-Up Light(SC400)

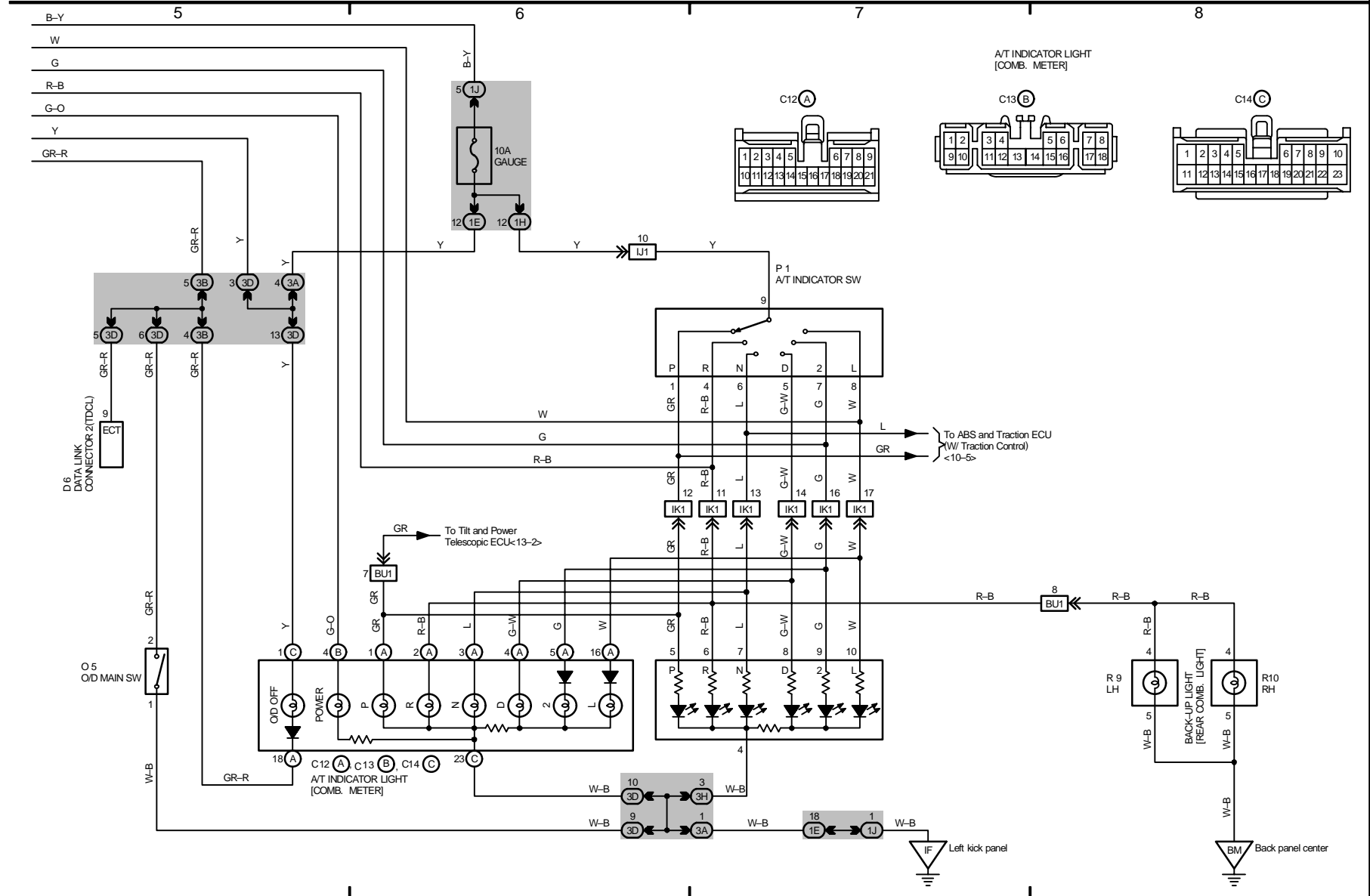

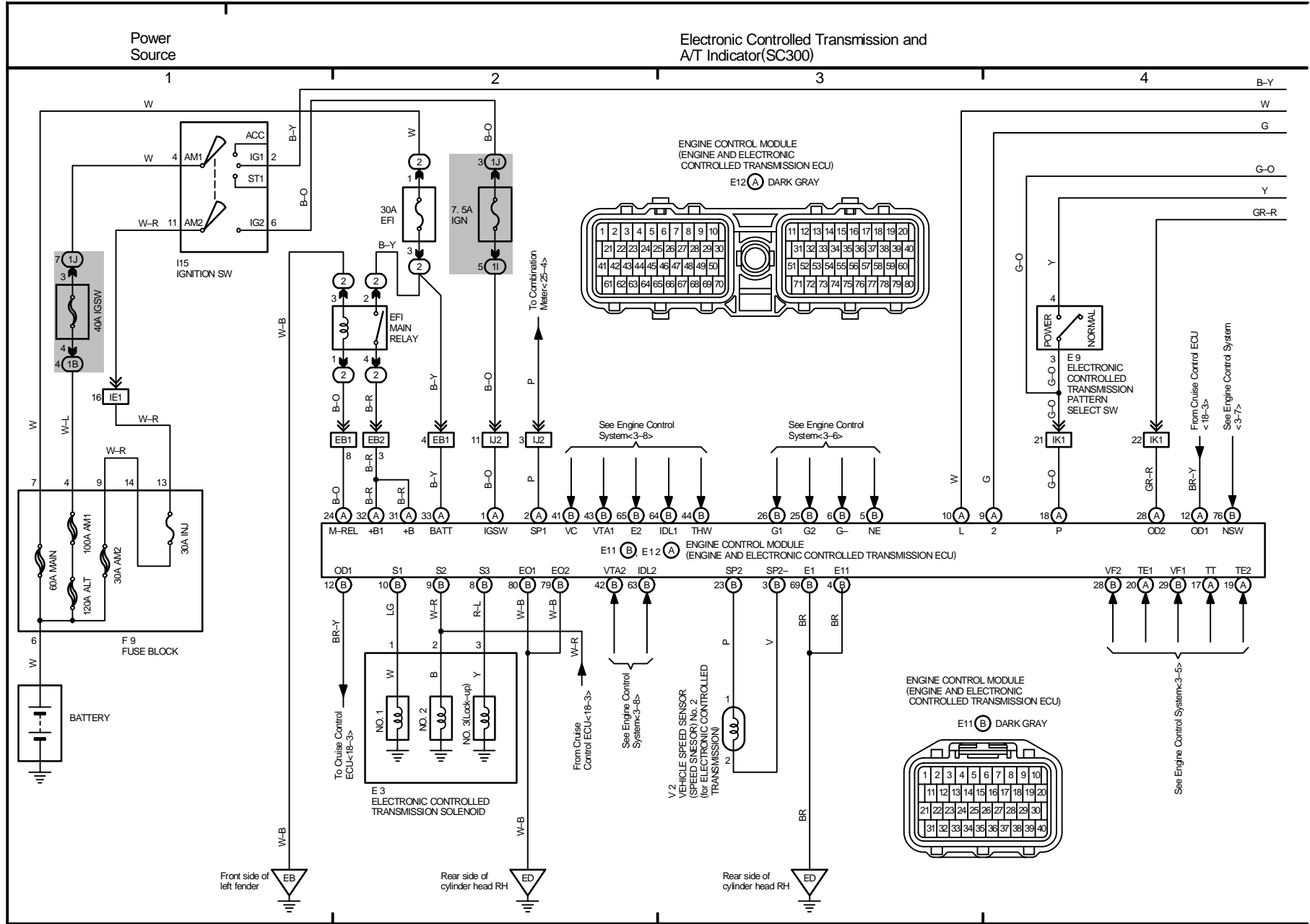

5 LEXUS SC400/SC300(Cont' d)

Electronic Controlled Transmission and A/T Indicator(SC300)

Back-Up Light (SC300)

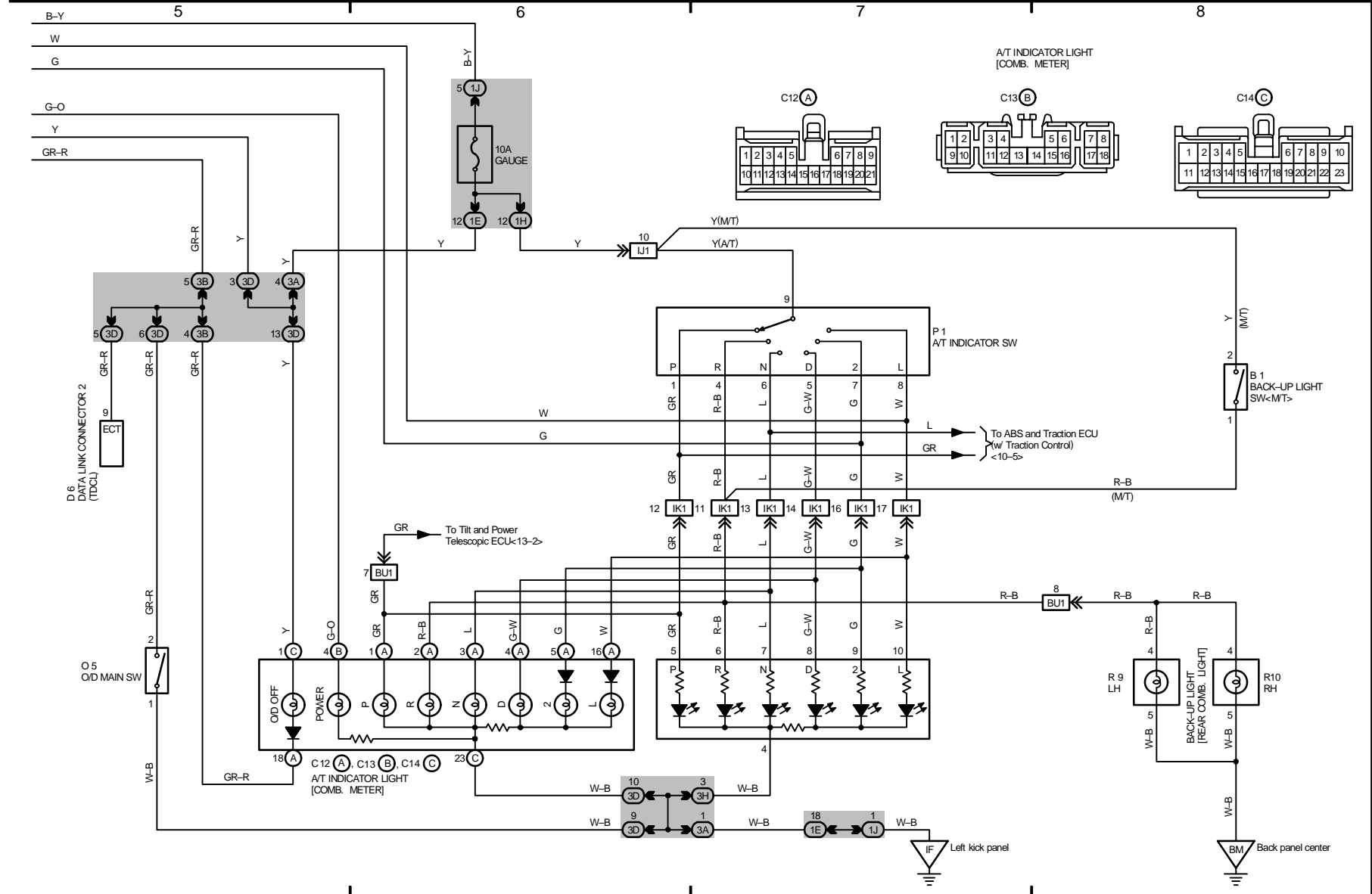

6 LEXUS SC400/SC300(Cont' d)

Taillight and Stop Light(for USA)

Illumination
(for USA)

- *1: w/ Rear Spoiler
- *2: w/o Rear Spoiler
- *3: w/ Memory Power Seat
- *4: w/o Memory Power Seat
- *5: SC300
- *6: SC400

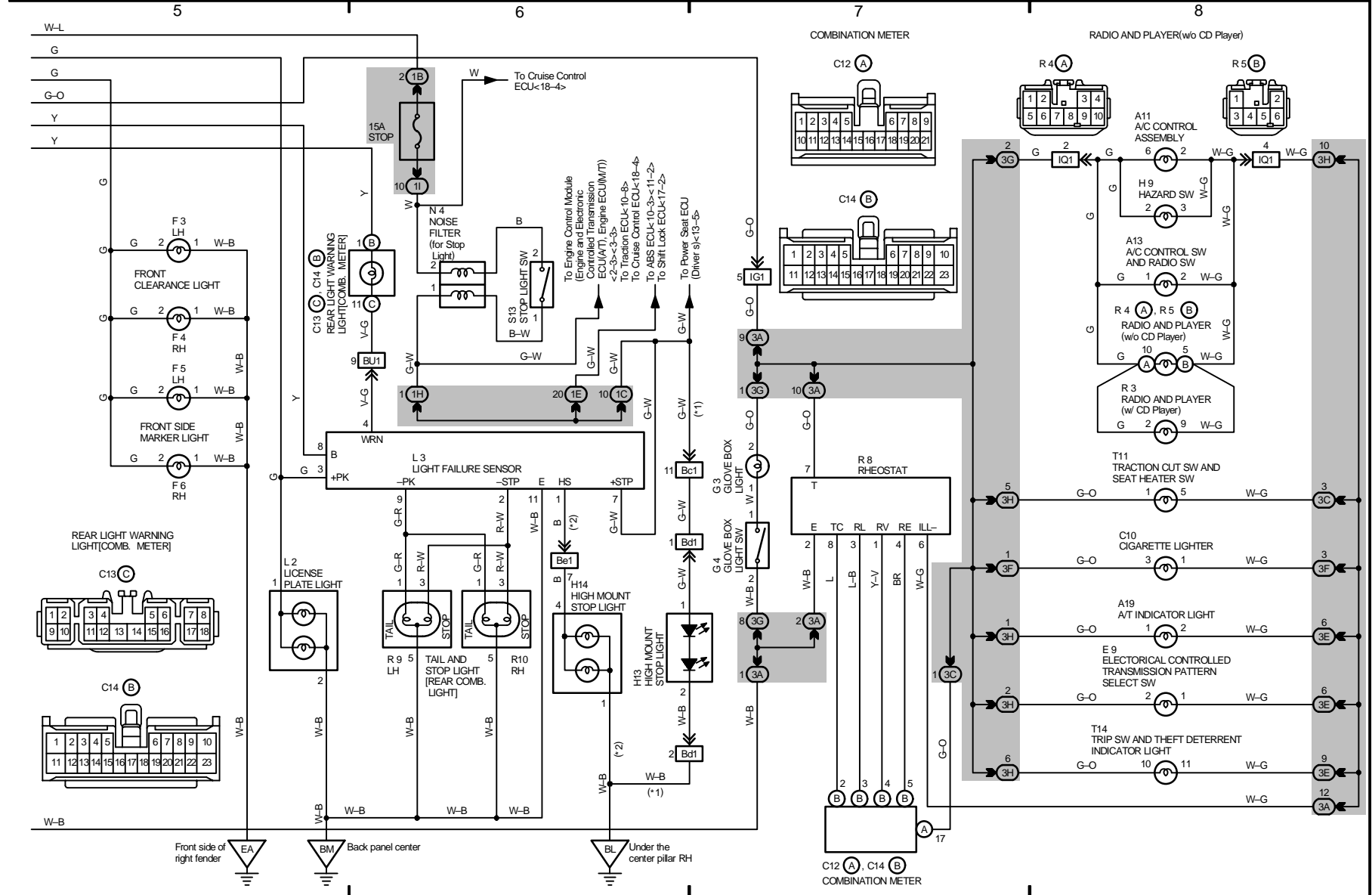

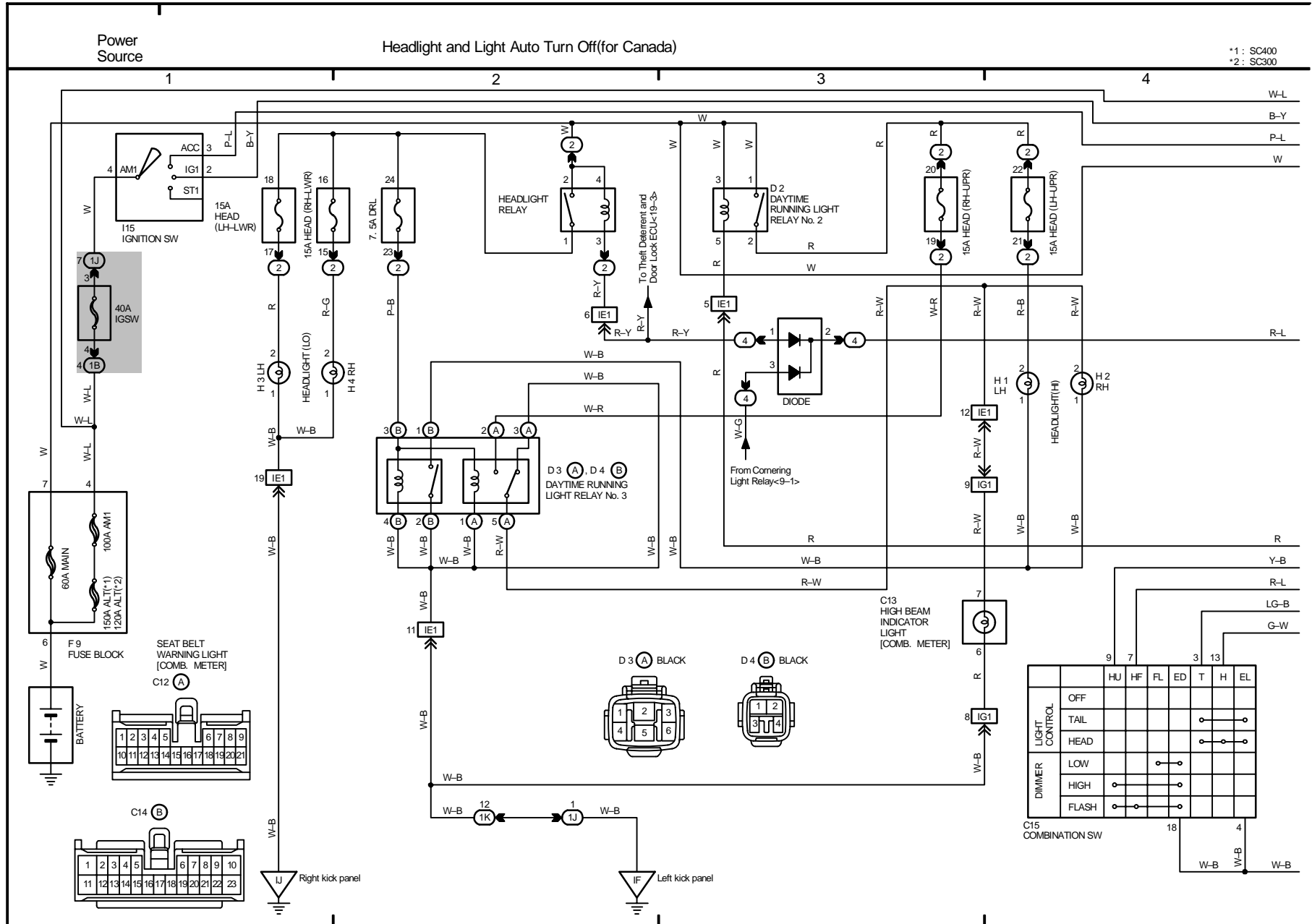

	9	7	3	13
LIGHT CONTROL	OFF	HU	HF	FL
	TAIL			
	HEAD			
DIMMER	LOW			
	HIGH			
	FLASH			

C15 COMBINATION SW

7 LEXUS SC400/SC300(Cont' d)

Unlock and Seat Belt Warning(for Canada)

Taillight and Stop Light(for Canada)

*1 : Engine and Electronic Controlled Transmission ECU(A/T), Engine ECU(M/T)
 *2 : w/ Memory Power Seat
 *3 : w/o Memory Power Seat

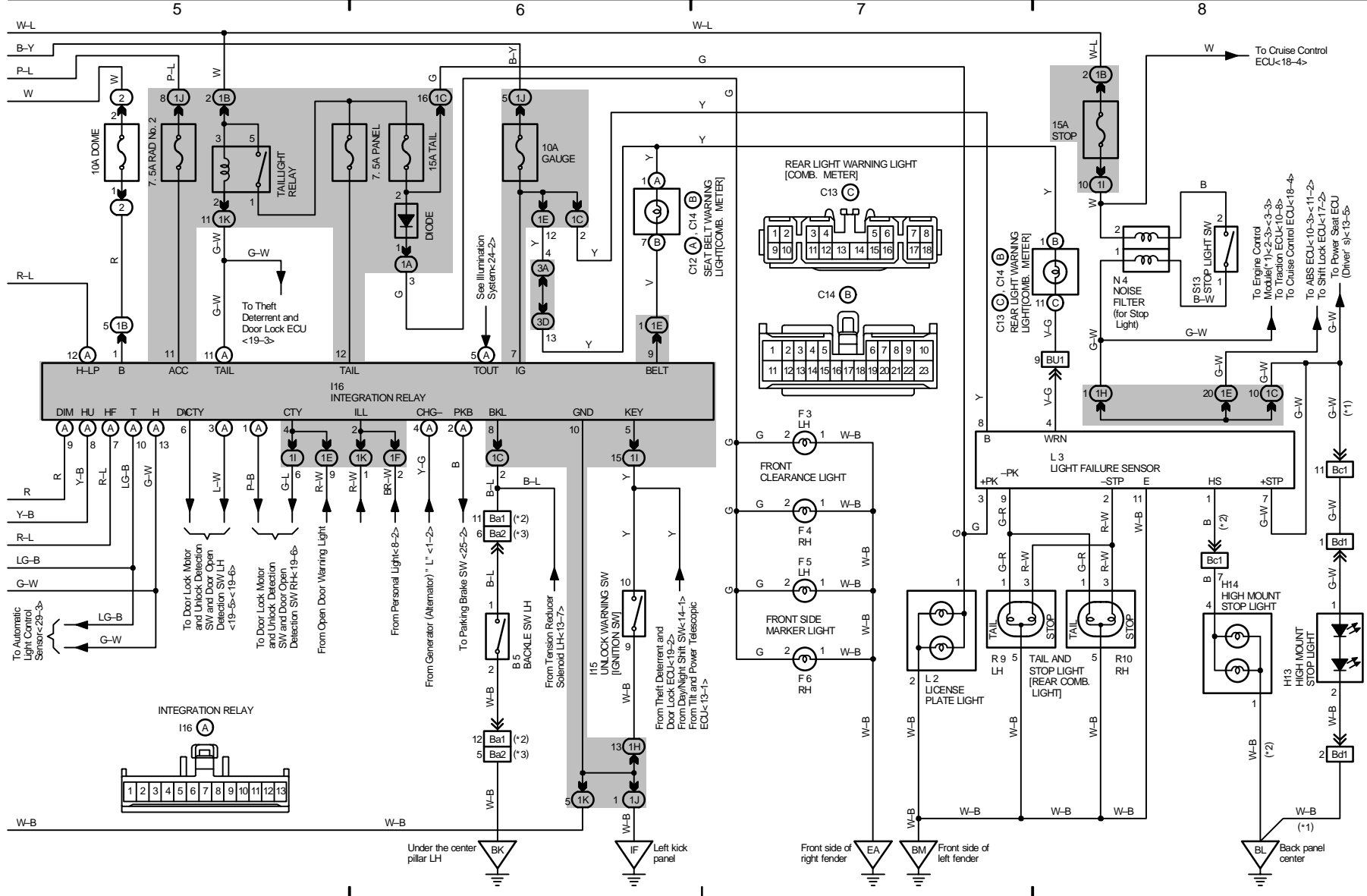

8 LEXUS SC400/SC300

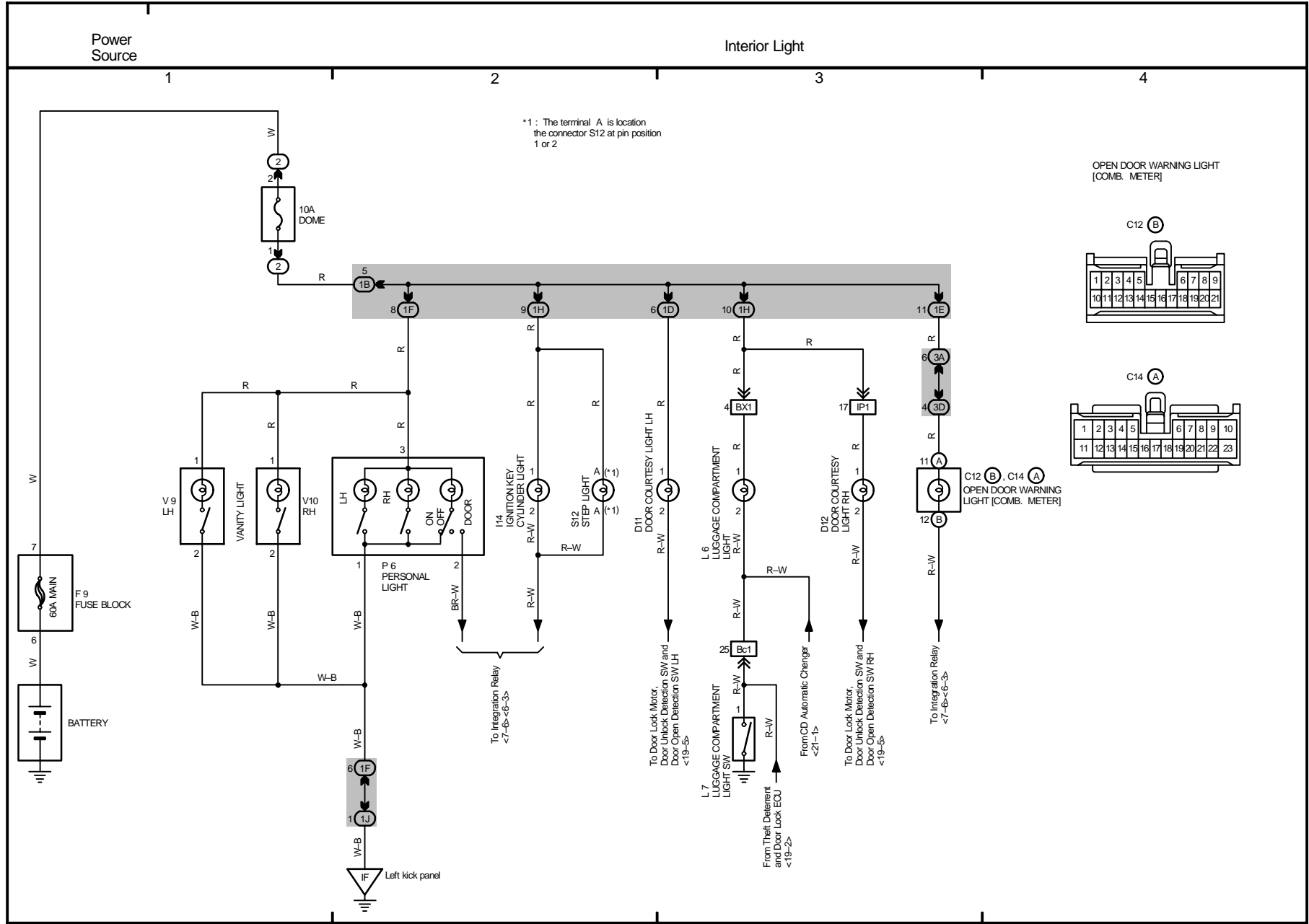

OVERALL ELECTRICAL WIRING DIAGRAM

10 LEXUS SC400/SC300(Corr' d)

ABS and Traction Control

- *1 : Engine and Electronic Controlled Transmission ECU
- *2 : SC400
- *3 : SC300

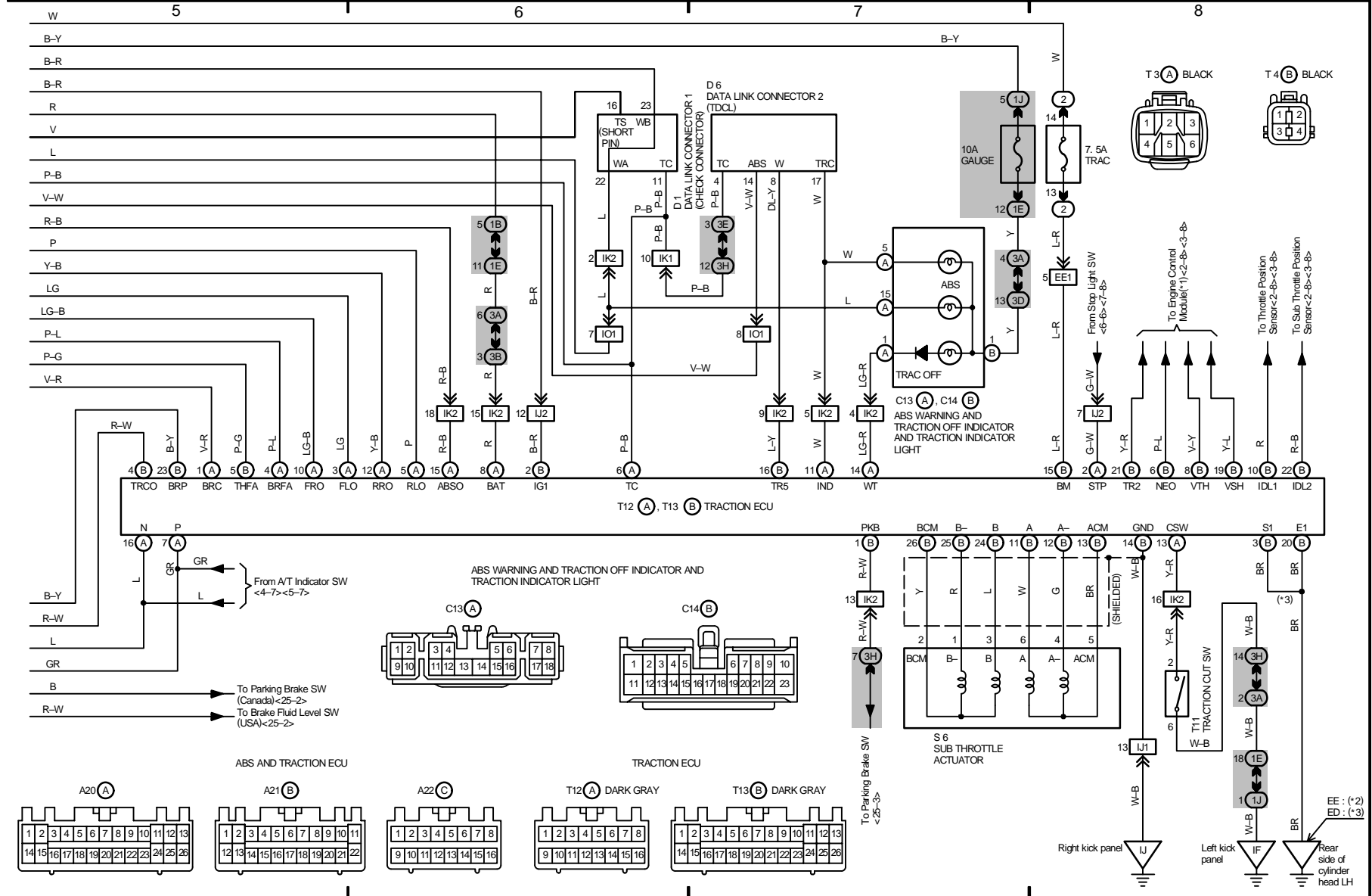

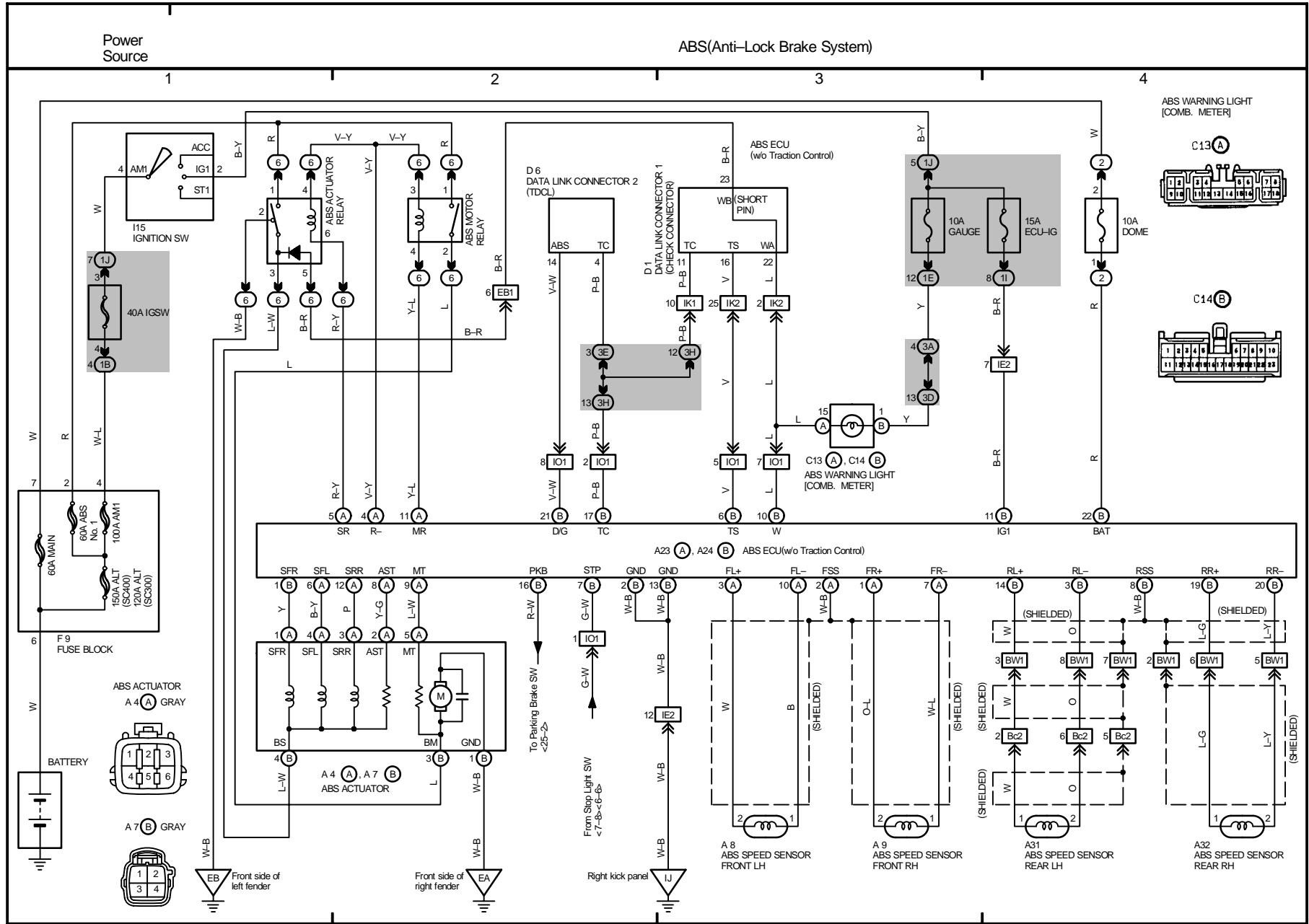

12 LEXUS SC400/SC300

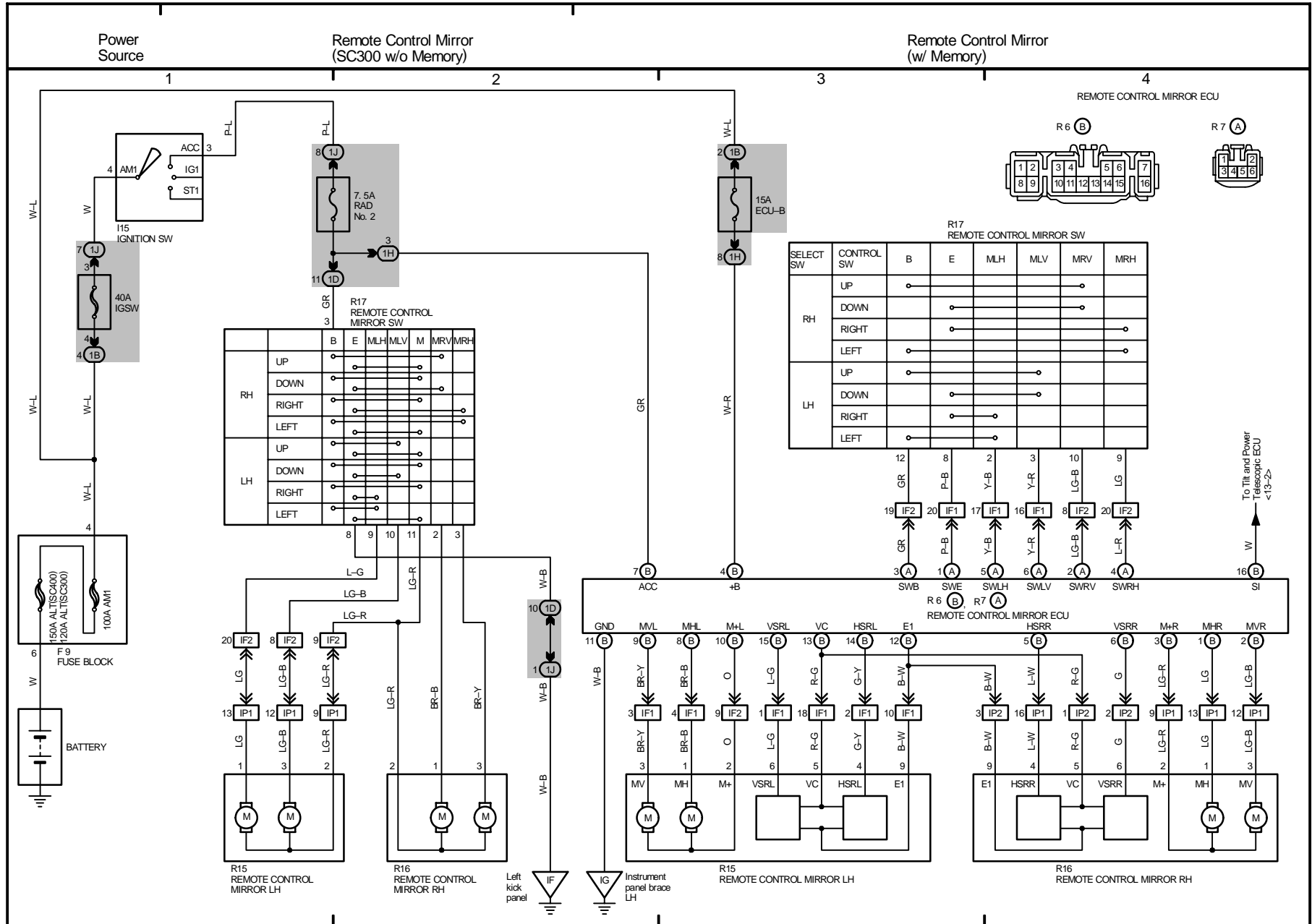

14 LEXUS SC400/SC300

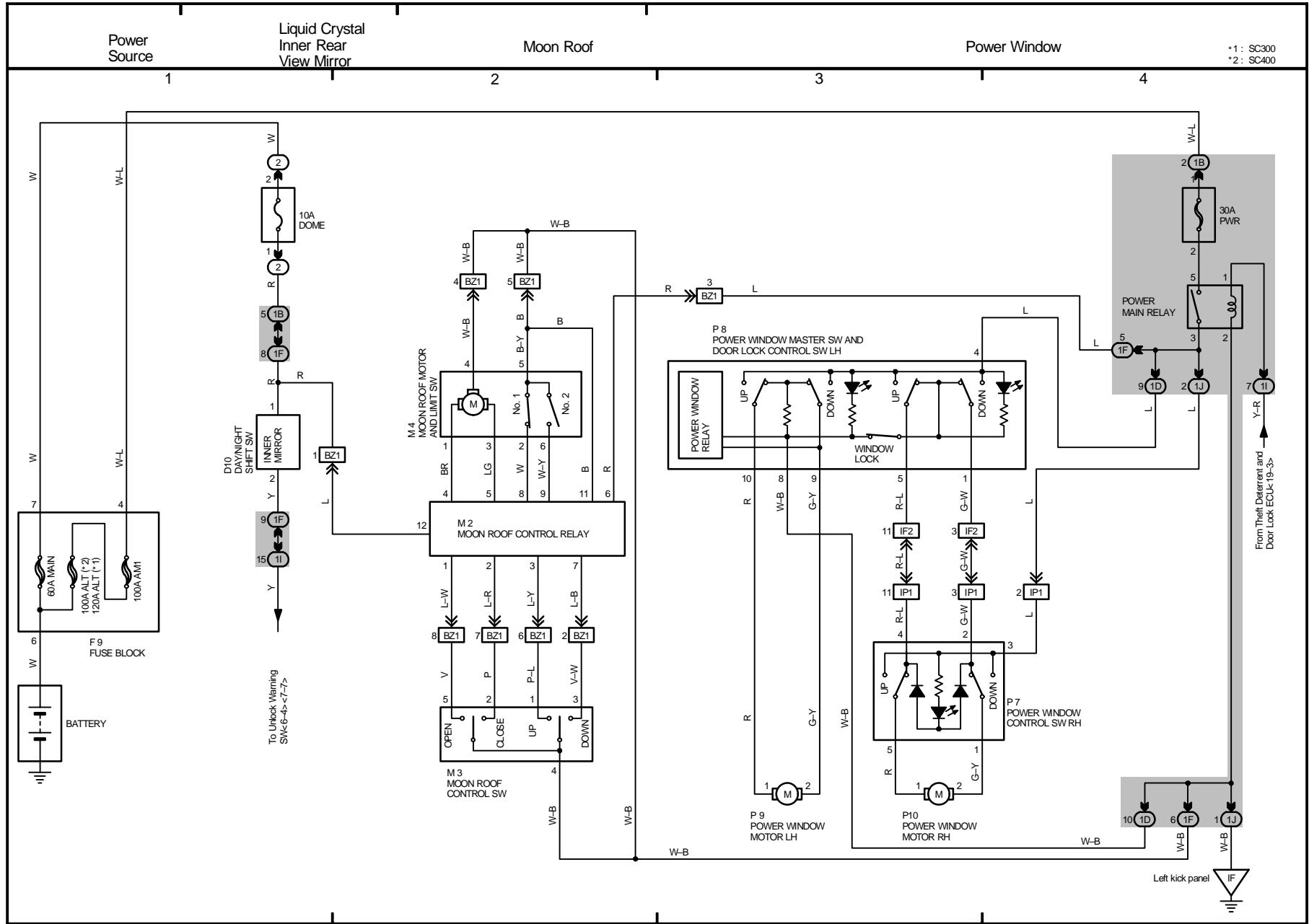

*1 : SC300
*2 : SC400

OVERALL ELECTRICAL WIRING DIAGRAM

15 LEXUS SC400/SC300

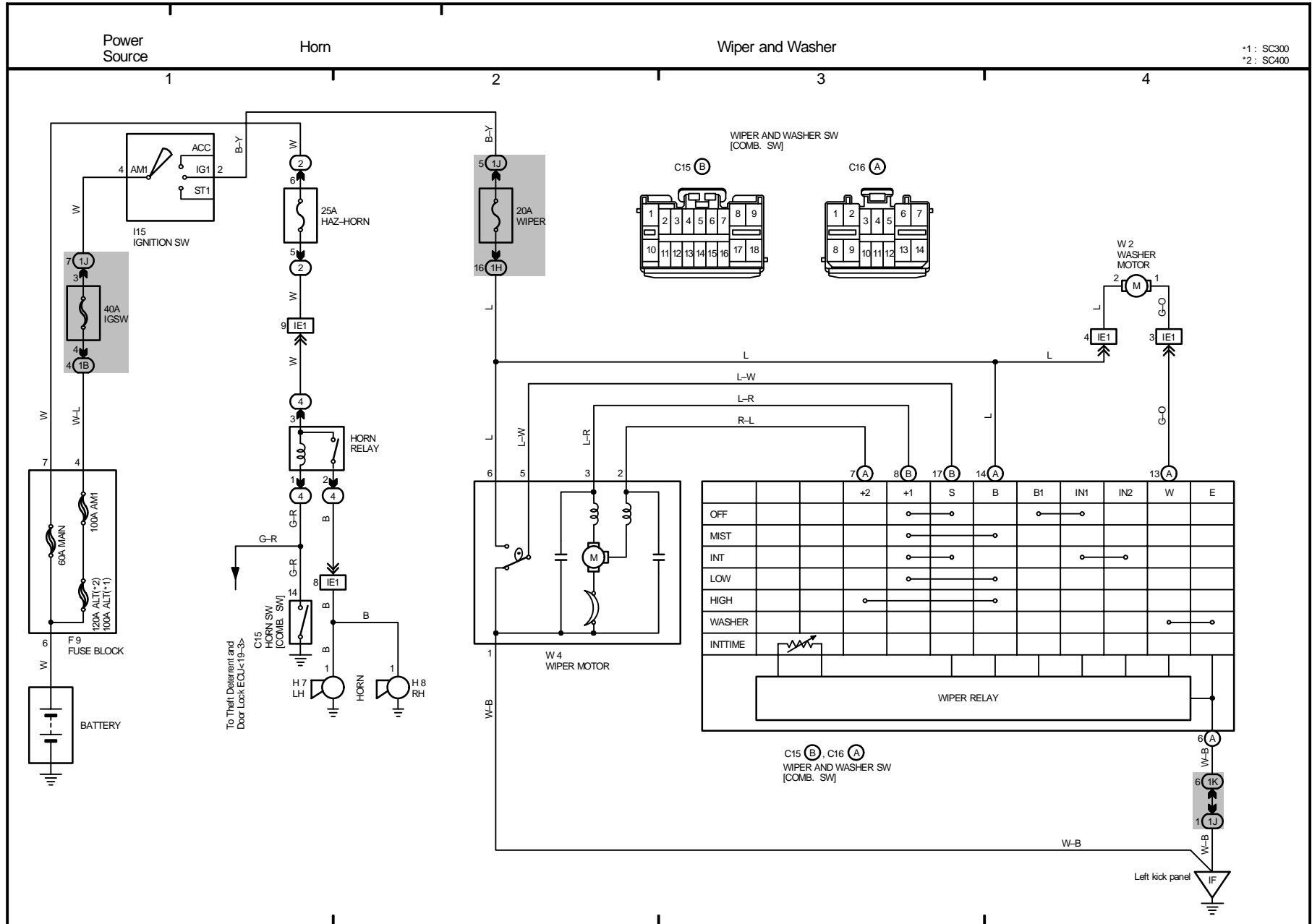

16 LEXUS SC400/SC300

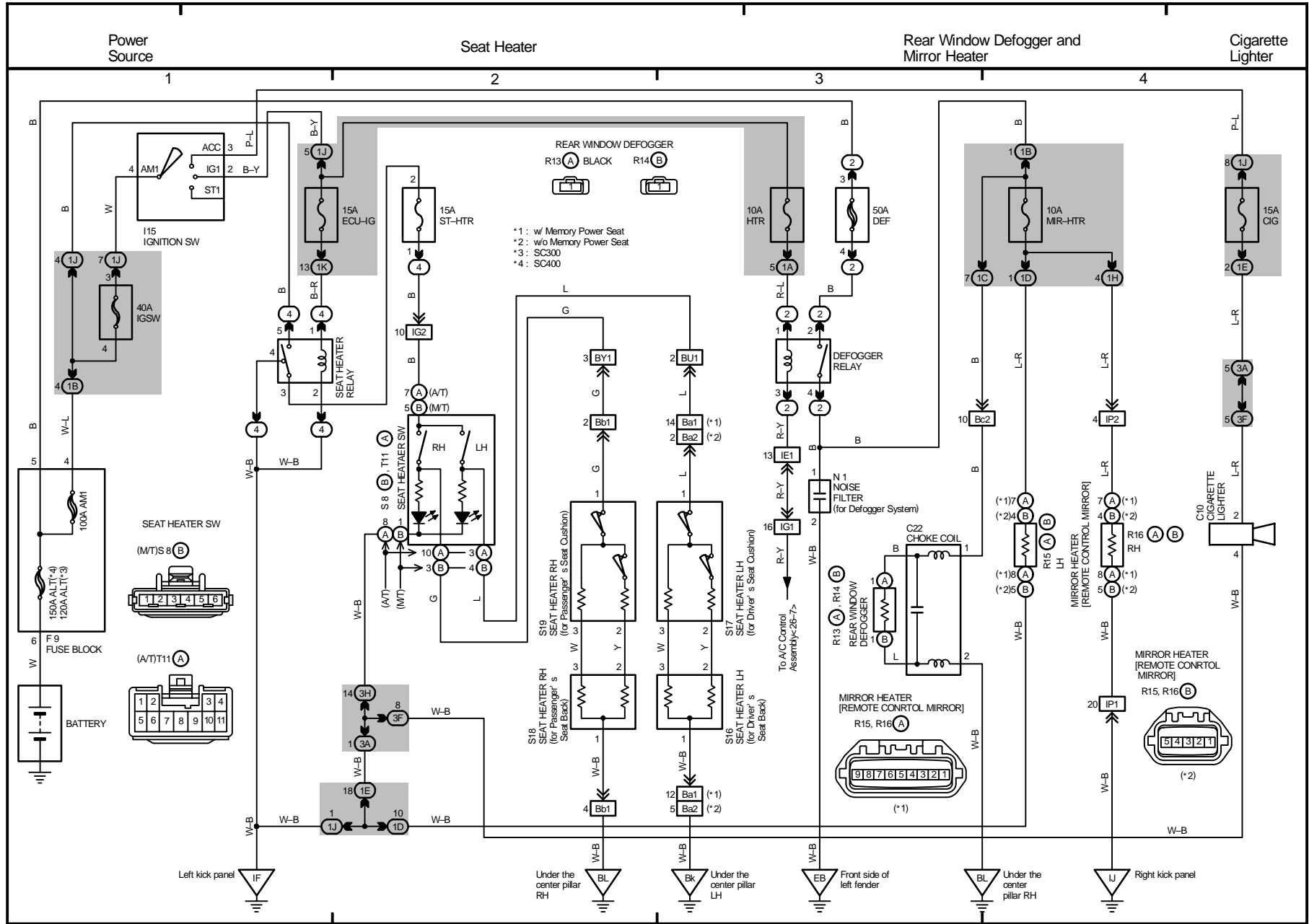

OVERALL ELECTRICAL WIRING DIAGRAM

17 LEXUS SC400/SC300

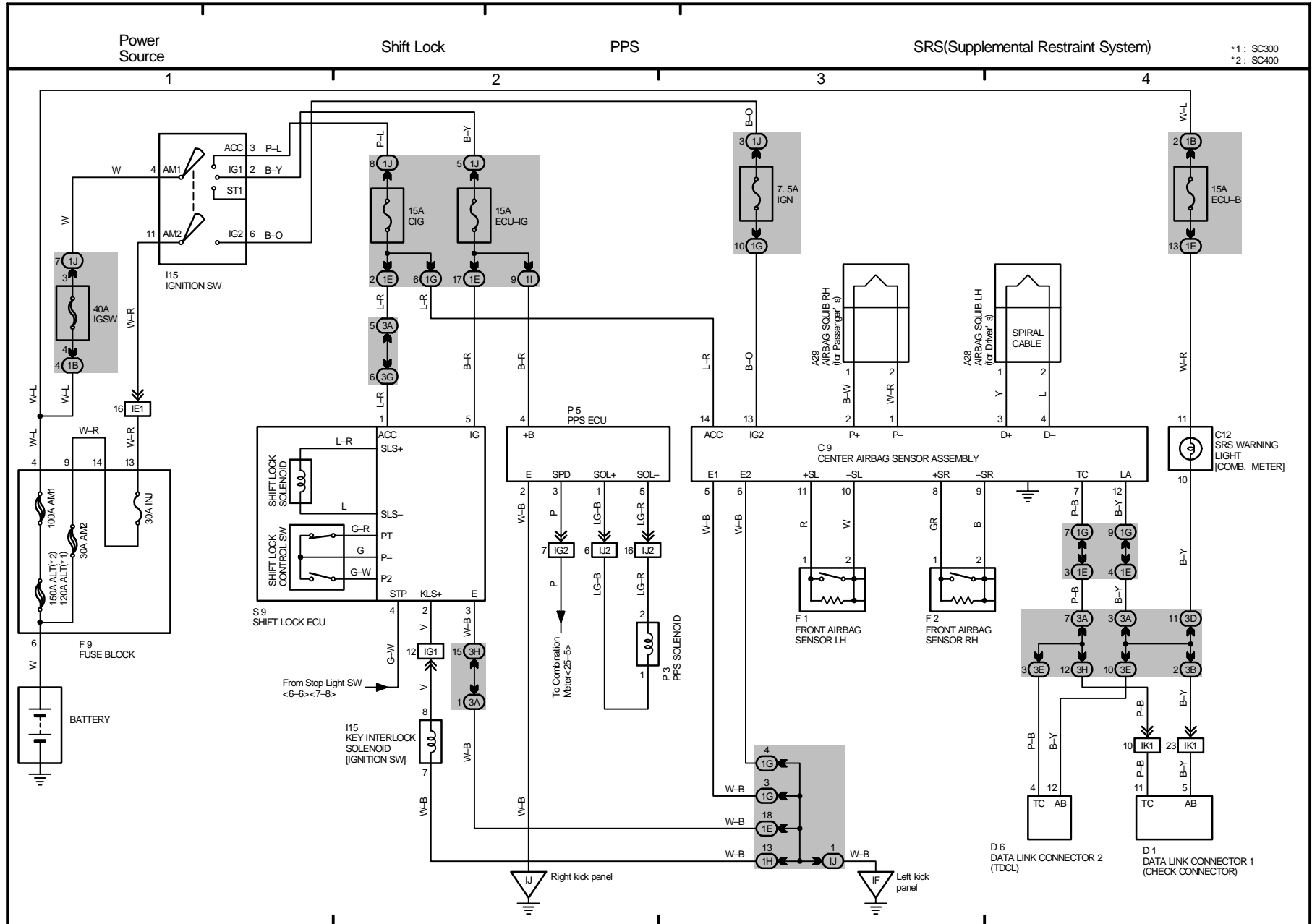

18 LEXUS SC400/SC300

OVERALL ELECTRICAL WIRING DIAGRAM

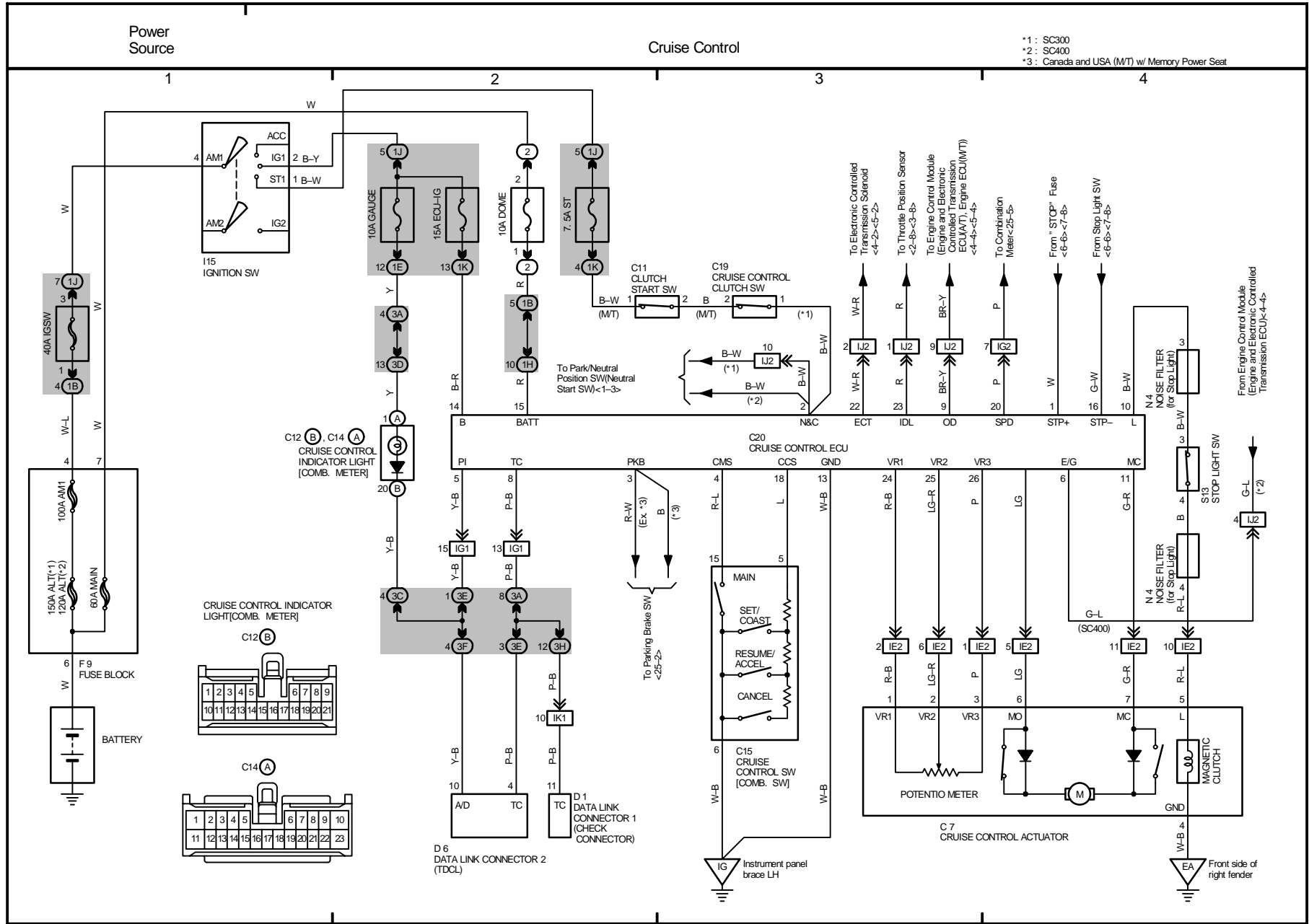

20 LEXUS SC400/SC300

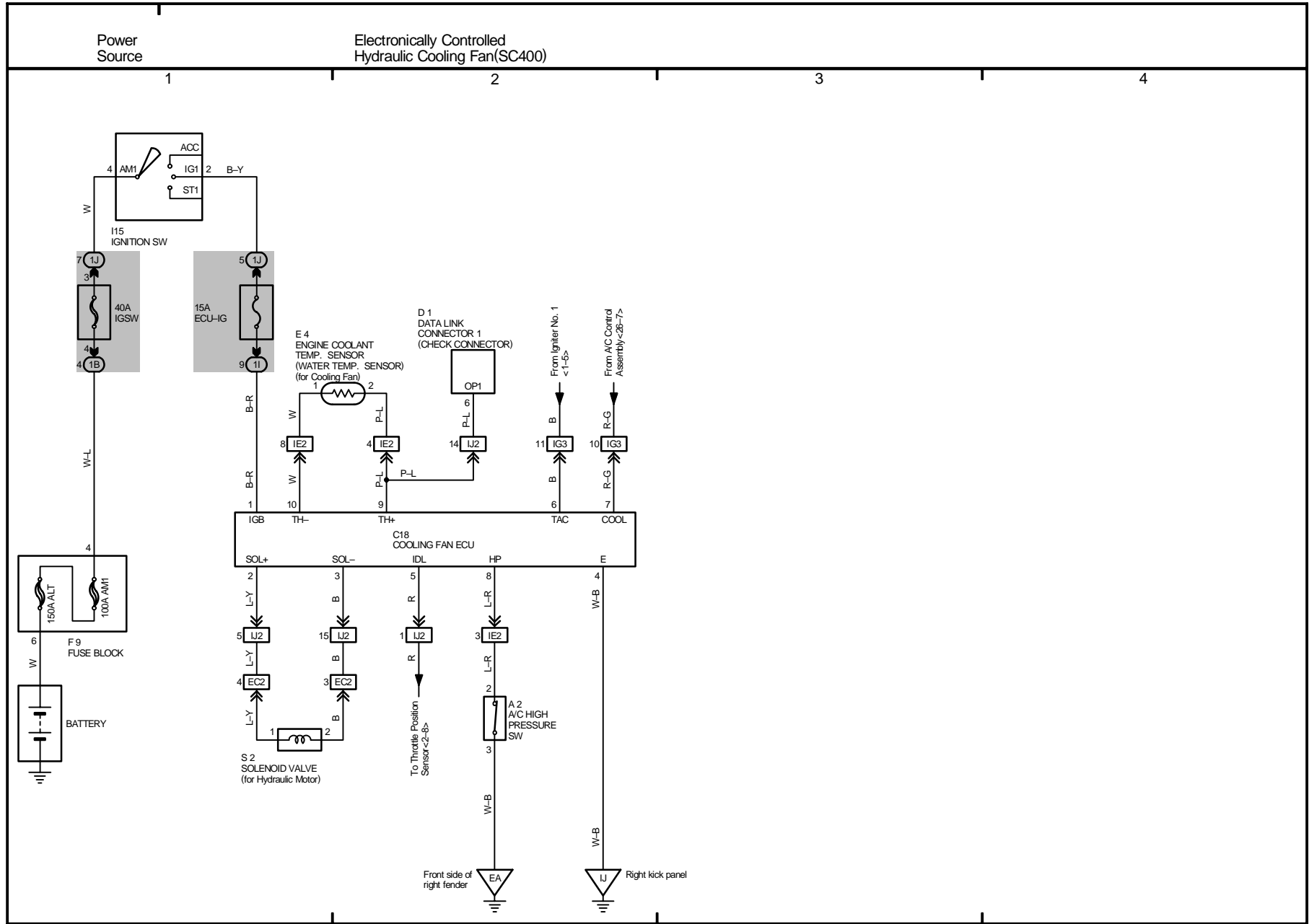

21 LEXUS SC400/SC300(Corr' d)

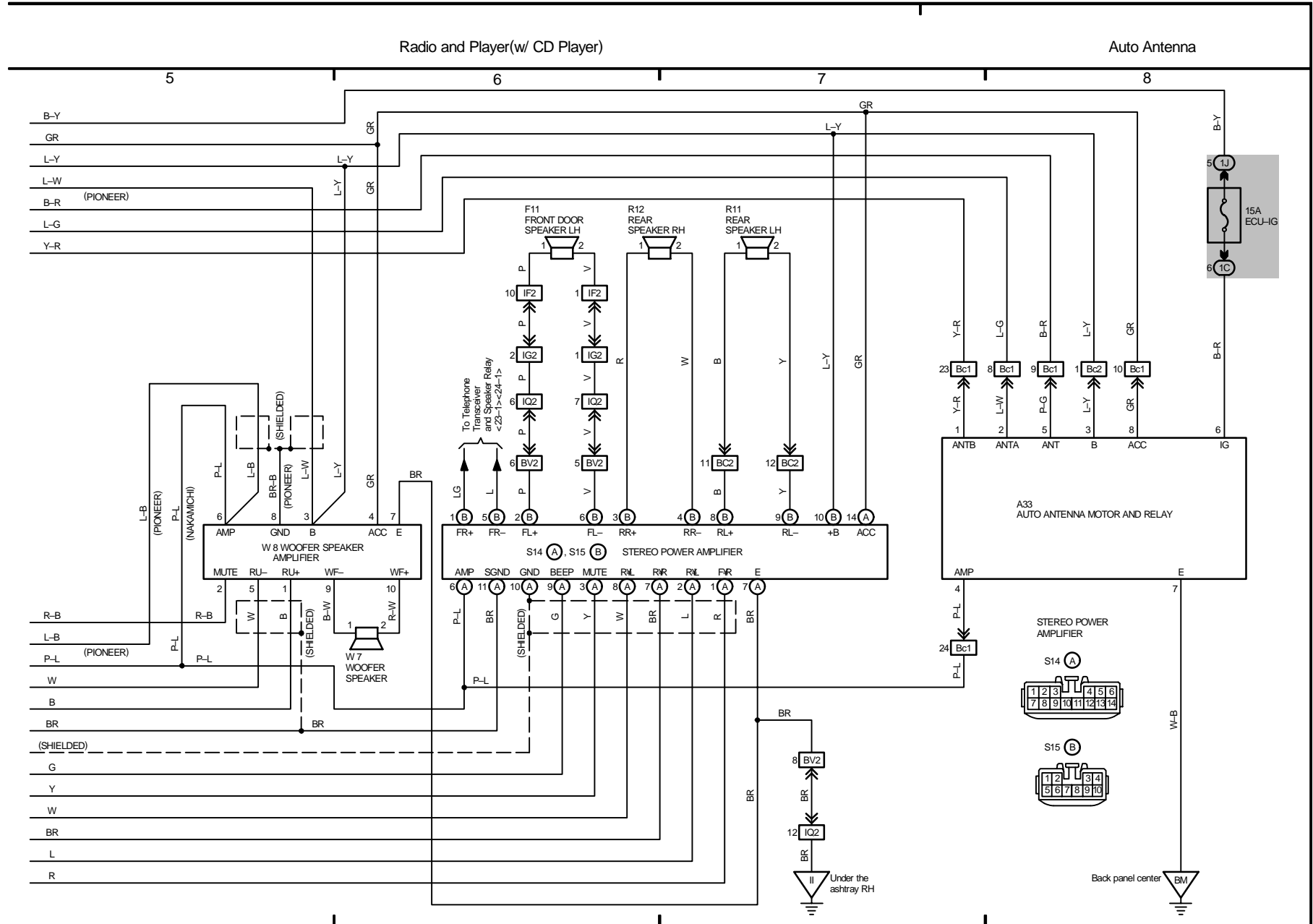

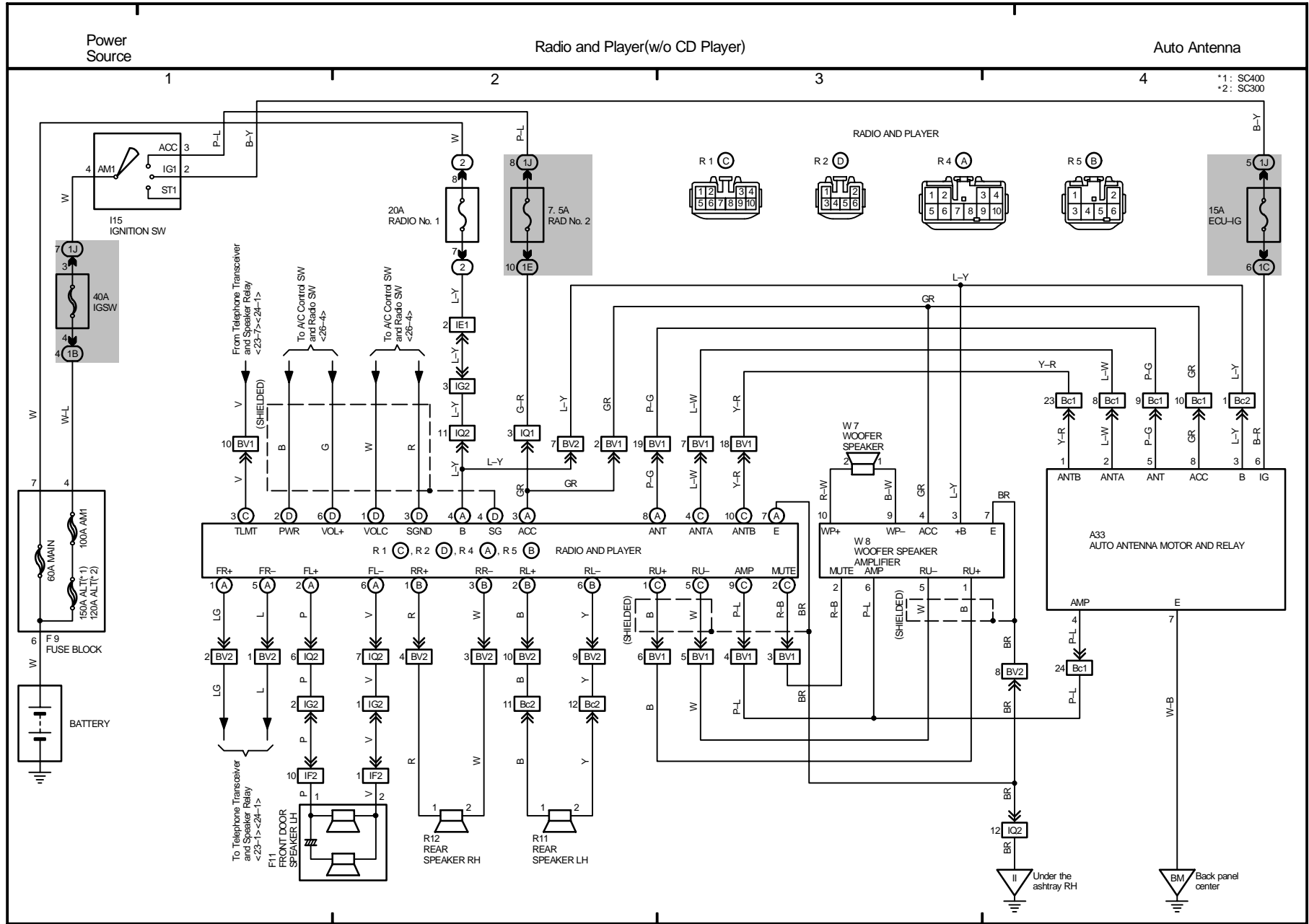

23 LEXUS SC400/SC300

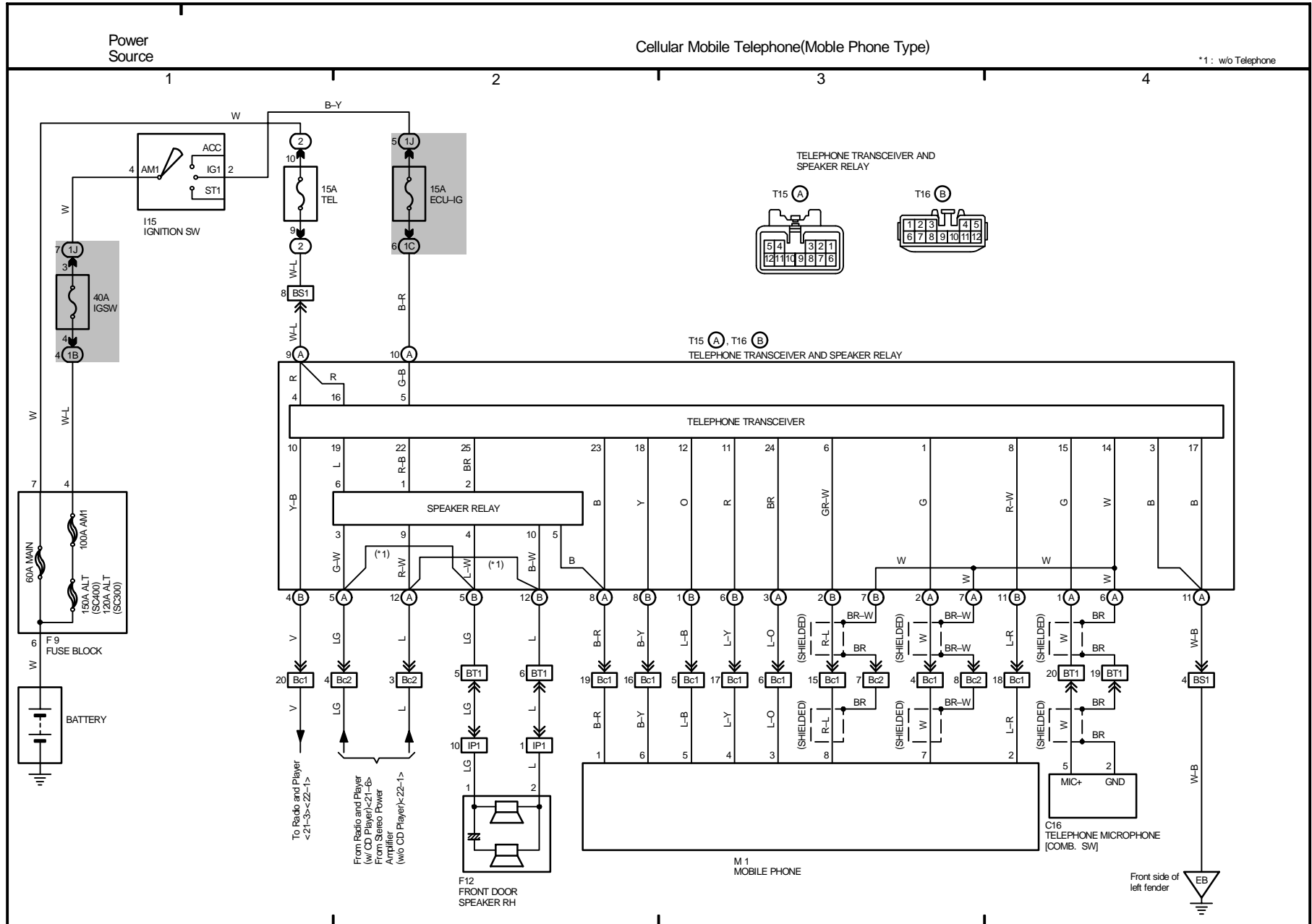

25 LEXUS SC400/SC300(Corr' d)

Combination Meter

*1 : Engine and Electronic Controlled
Transmission ECU(A/T), Engine ECU(W/T)
*2 : Malfunction Indicator Lamp
(Check Engine Warning Light)

*3 : SC400
*4 : SC300

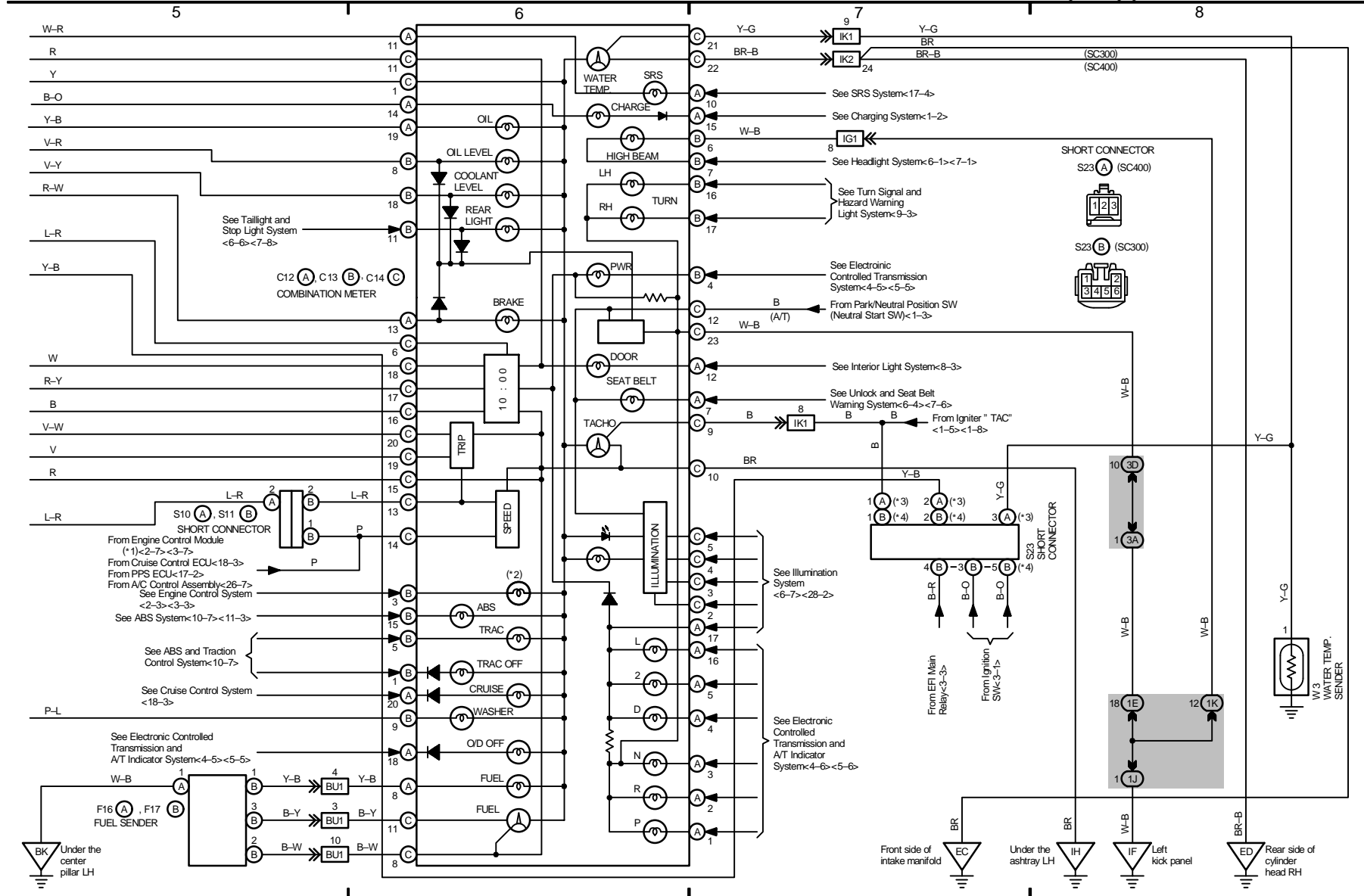

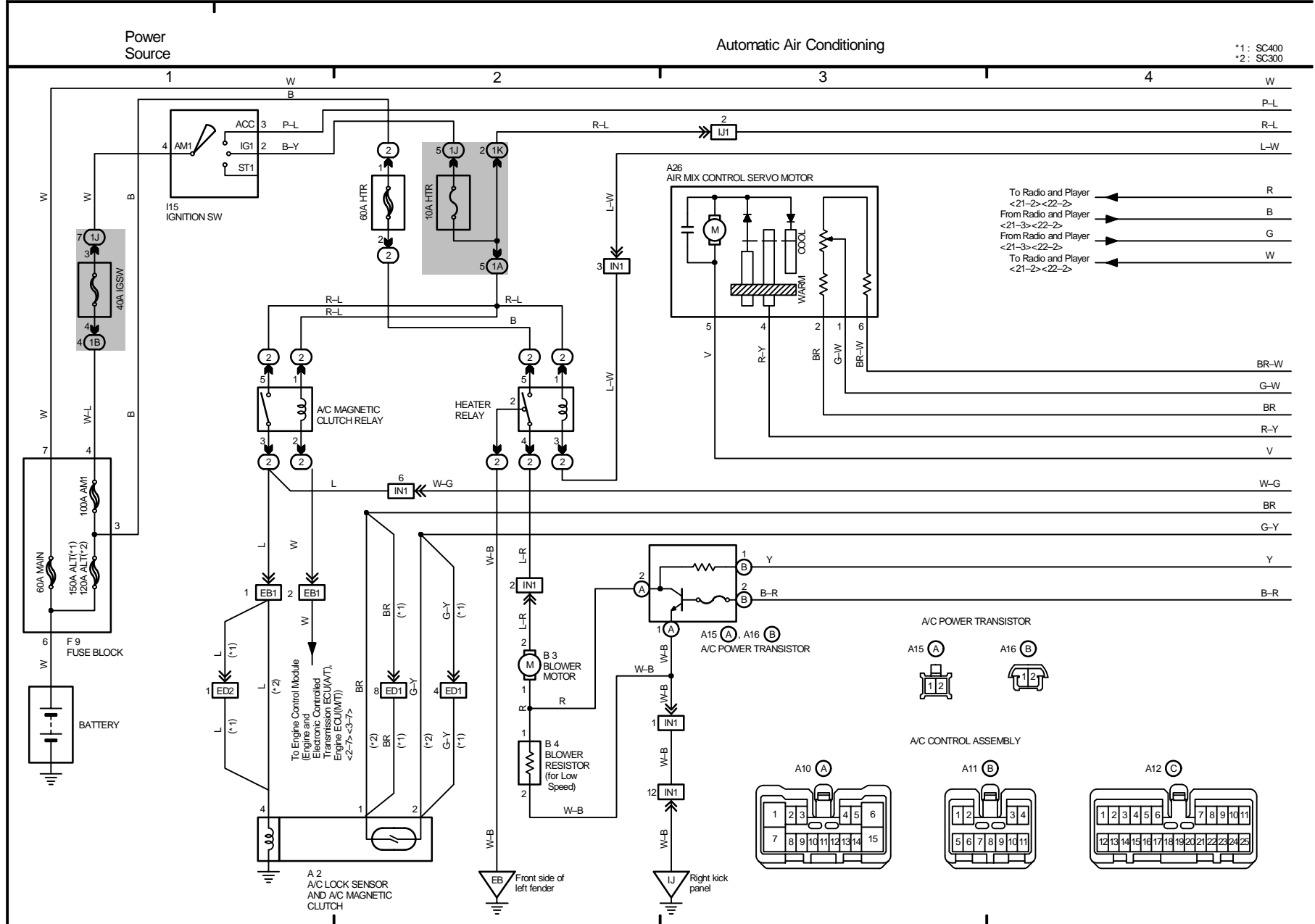

Automatic Air Conditioning

*1 : Engine and Electronic Controlled Transmission ECU(A/T), Engine ECU(M/T)

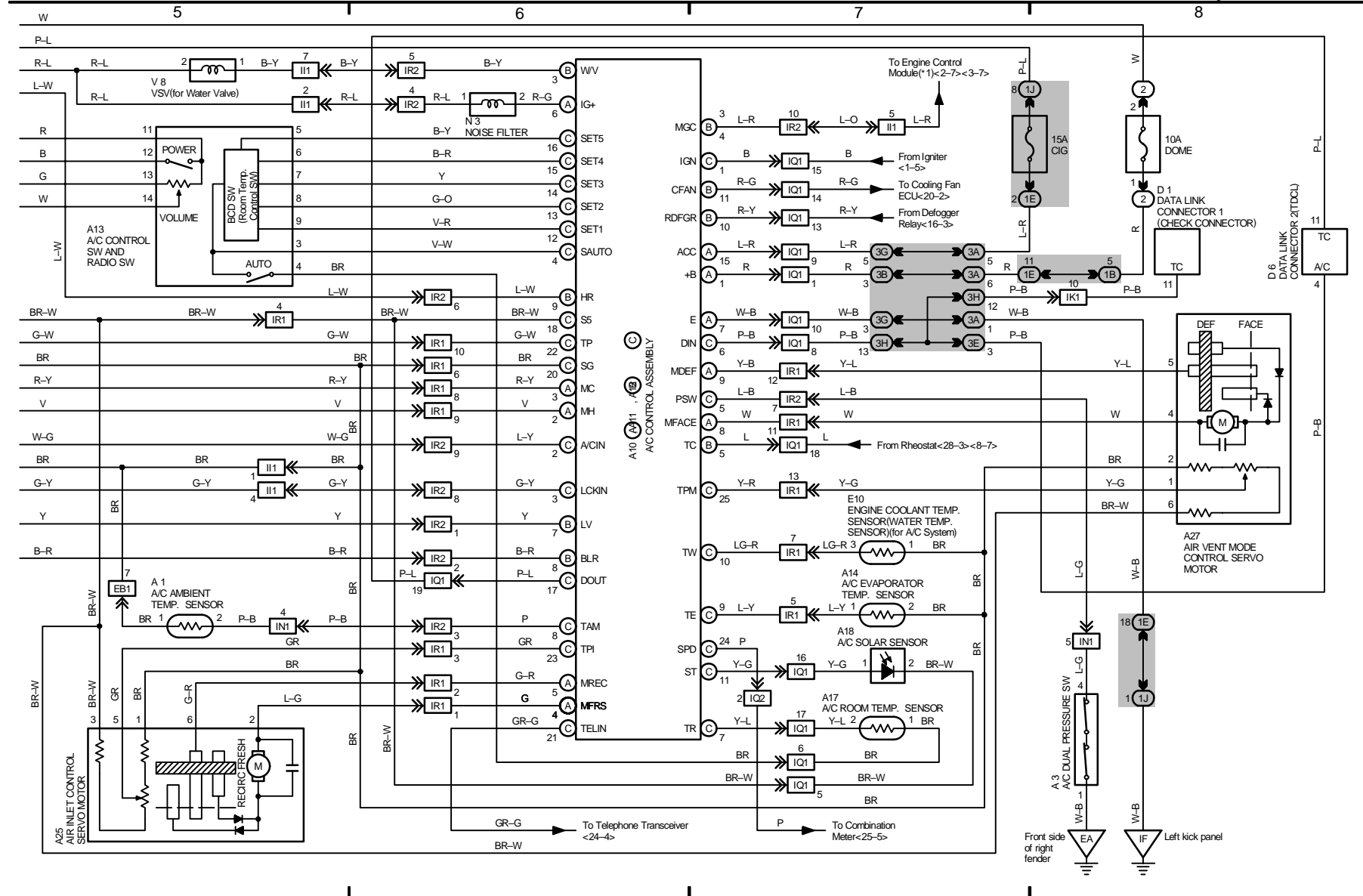

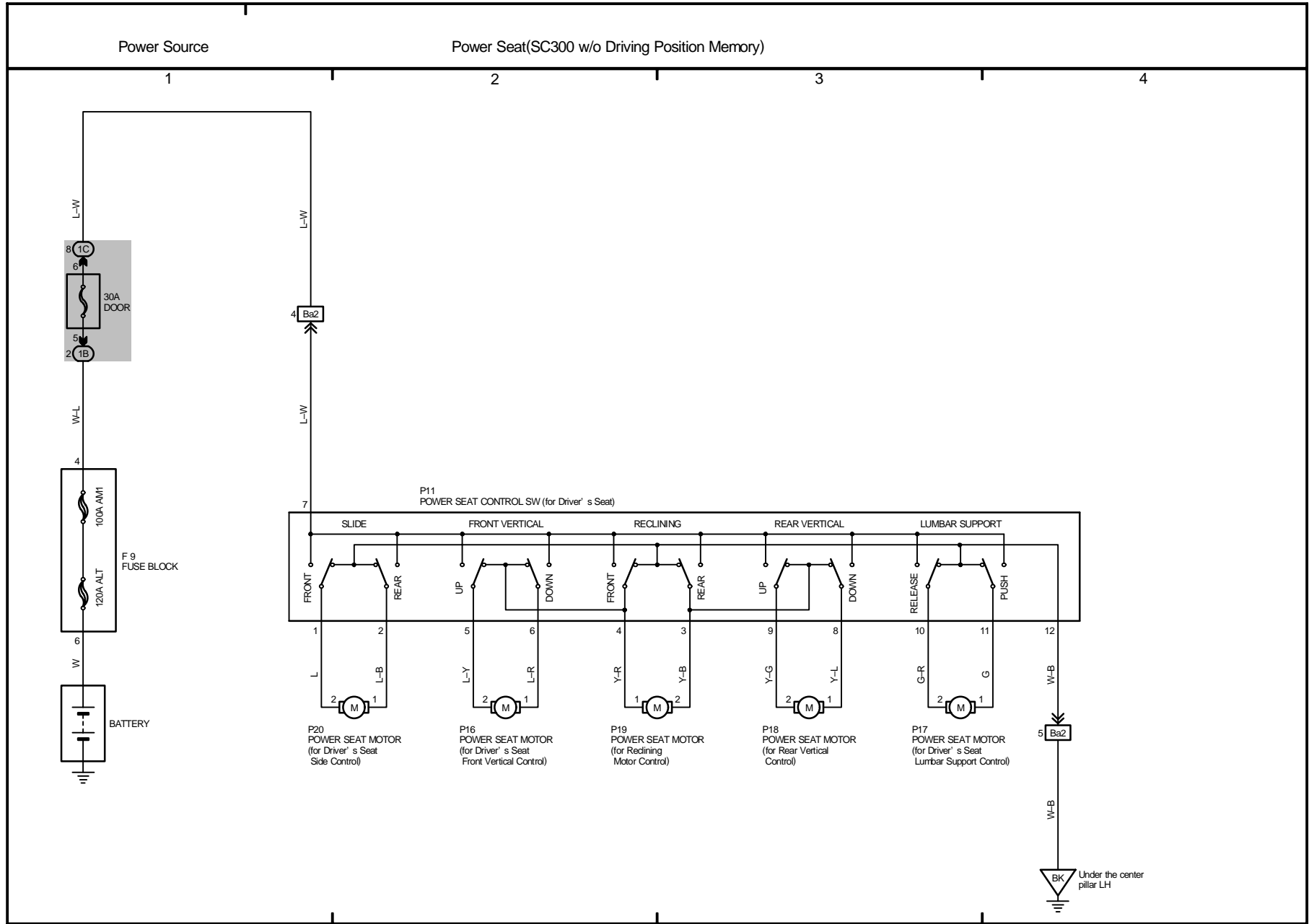

28 LEXUS SC400/SC300

